

1 UPPER BRACKET & SUPPORT ARM KIT AND INSTRUCTIONS

Is the bike clean? Did you read the "GMIA" instructions?

Kit Includes:	Qty.	Extra
Mounting Bracket: Left / Clutch Side	1	0
Mounting Bracket: Right / Brake Side	1	0
Mounting Bracket Support Bar	1	0
Stainless Steel Nylock® Machine Screw	2	0
Mtg. Bracket Stop Adhesive Pad (1/2" x 9/16")	2	1
Velcro Strip: (1/4" x 1")	2	1
Alcohol Pad	1	0

Requires 1/4" or 6mm Allen Wrench and Masking Tape

IMPORTANT INFORMATION: PLEASE READ

K12RS drivers can use the Bracket Support Bar as a "Handle" for raising and lowering screen (at your own risk). It is generally safer to pull off the road and stop in a safe location before adjusting the windscreen. If you decide to raise the windscreen while traveling, do not raise screen at speeds over 70 mph. Air pressure on screen makes it too difficult at higher speeds. Instead, give yourself enough distance from traffic behind you, slow down, raise screen, check mirrors, and if conditions are safe, resume speed.

Caution! Manually adjusting windscreen while driving may jeopardize your safety. It is the complete responsibility of the driver to determine his/her risk as to whether it is safe to use the Bracket Support Bar as a handle to raise or lower the windscreen during travel.

UPPER BRACKETS AND SUPPORT ARM

NOTE: BOTTOM OF BRACKET STOPS STAMPED "L" OR "R"
"L" = LEFT/CLUTCH-SIDE, "R" = RIGHT/BRAKE-SIDE

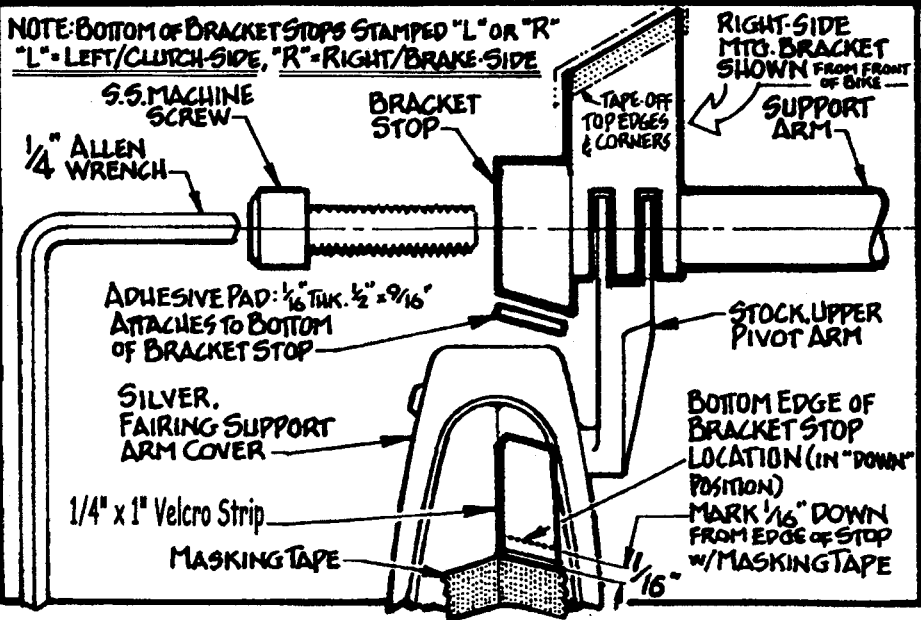

UPPER BRACKET & SUPPORT ARM MTG.

NOTE: Before starting, cover top edges and corners of brackets with masking tape to prevent possible scratching of screen or bike until ready to mount screen.

- 1. Clean bottom of bracket "Stops" with alcohol pad and wipe dry. You will note an "L" or "R" stamped on the bottom of the "Stops." "L" = left/clutch side, "R" = right/brake side. Peel backing from the 1/2" x 9/16" clear rubber pads and place on the bottom of the "Stops."**
- 2. Mount brackets and Support Bar to stock pivot arms as shown. Do not over tighten – brackets must rotate freely.**
- 3. Lower brackets until the Stops contact the silver fairing support-arm cover. Mark cover with tape 1/16" below bottom edge of Stops. See drawing.**
- 4. Raise/rotate arms back. Clean support arm cover with alcohol pad at location marked with tape and wipe dry. Attach Velcro strip to covers, as shown, to keep them from scuffing as screen is raised and lowered.**

UPPER BRACKET MOUNTING SEQUENCE

UPPER MTG. BRKT.

MTG. SCREW

SUPPORT
ARM

FITS AGAINST
SIDE OPPOSITE
OF BRKT. STOP.

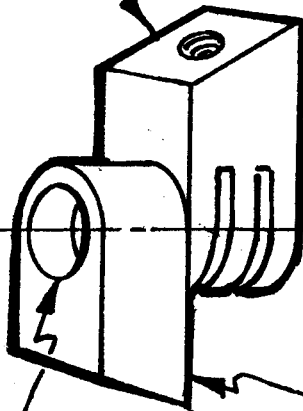
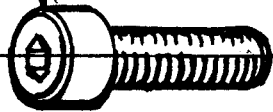

NOTE:

COUNTERBORE IN
BRKT. STOP IS FOR
HEAD OF MTG. SCREW

BRACKET
STOP